

TEC (Peltier) Controller PLC-24V10AL Reference Manual (Rev.1.00)

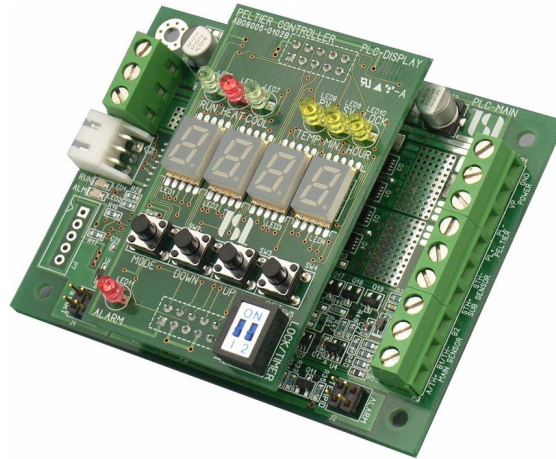

Thank you for purchasing the TEC (Peltier) Controller **PLC-24V10AL**.
Read these operating instructions carefully to ensure effective use of all the performance this product as to offer, and then use the product properly.
In particular, **please be sure to read "Cautions on use" before use.**
After reading these operating instructions, be sure to store them in a place where they can be readily consulted whenever necessary.

This reference manual explains detailed functions and advanced usage of the TEC (Peltier) Controller **PLC-24V10AL**.
For basic usage, please refer to the quick start manual.

Technical support and after-sales service

About support, such as an inquiry about this product, a request for repair, and download of application software, and after-sale service, it is accepted at the Kurag Electronics website. Please contact the address listed below.

KURAG ELECTRONICS WEB site: <http://kurag.o.oo7.jp/kurag-el/>

E-mail (Peltier Controller Support): kurag.tslab@biz.nifty.jp

KURAG ELECTRONICS LLC



KURAG
ELECTRONICS

Table of contents

1. Cautions on use _____	Page 3
2. General _____	Page 4
3. Contents _____	Page 5
4. Names of parts and functions (Main board) _____	Page 6
5. Names of parts and functions (Display board) _____	Page 7
6. Setting and connection _____	Page 8
6-1. Setting of power supply voltage _____	Page 8
6-2. Setting of alarm / protection functions _____	Page 10
6-3. Setting of temperature sensor type _____	Page 11
6-4. Setting of PID control parameters _____	Page 12
6-5. Connection _____	Page 13
6-6. Connection diagram (Single power supply) _____	Page 16
6-7. Connection diagram (Dual power supply) _____	Page 16
7. Operation _____	Page 17
7-1. Basic operation by key operation _____	Page 17
7-2. Temperature indication of sub temperature sensor _____	Page 17
7-3. Operation procedure of continuous mode _____	Page 17
7-4. Operation procedure of timer mode _____	Page 18
7-5. Operation procedure of lock mode _____	Page 19
8. Alarm / Protect / Indicator functions _____	Page 20
8-1. Alarm functions _____	Page 20
8-2. Reverse protection _____	Page 21
8-3. Indicator function _____	Page 22
9. Specifications _____	Page 23

1. Cautions on use

- ✓ The use of Kurag Electronics (KE) products with production equipment for the manufacture of weapons of mass destruction (WMD) or any other weapon is strictly prohibited.
- ✓ The exports of KE products or technology from one country to another are governed by the relevant security laws and regulation of the countries involved in the transaction. Prior to shipment of KE product to another country, assure that all local rules governing that export are known and followed.
- ✓ You agree to comply with all applicable international and national laws that apply to the Product, including Japanese Export Trade Control Order, as well as end-user, end-use, and destination restrictions issued by Japanese and other governments.
- ✓ We can bear absolutely no responsibility whatsoever for any direct or indirect damage that may occur due to the use of this product in your applications.
- ✓ This product is to be used with general industrial product. This product is not designed or manufactured to be used under such special conditions and environments as nuclear energy control, aerospace, transportation, medical equipment, various safety equipment or equipment which require high level reliability related human life. We assume no liability for any direct or indirect damages that may occur due to applying this product to such equipment or apparatus.
- ✓ If you notice smoke, strange smells or noise coming from the product, cut off the power supply. Continued use of the product in these conditions will result in fire or electric shock.
- ✓ If a liquid like water or foreign objects like pins and clips which have conductivity adhere to the product, cut off the power supply immediately. Continued use of the product in these conditions will result in fire or electric shock.
- ✓ If the product is dropped or strongly shocked or excess power added, cut off the power supply immediately. Continued use of the product in these conditions will result in fire or electric shock.
- ✓ When electric power is connected to the product, be careful to apply the proper voltage specified in the product specification. Improper voltage may cause malfunction or destroy the circuit. Moreover, please do not use it with the power supply voltage exceeding the rated voltage/current of the Peltier device to be connected. (A same voltage is supplied to the Peltier device.) Please confirm the polarity of connections. If a mistake made, regarding polarity, it may result in fire or electric shock, and it may cause malfunction of the product or Peltier device.
- ✓ When you install this product into equipment or wiring the circuit, don't turn on the power until work is completed. A large current flows into wiring of a power supply or a Peltier device. So please select the wiring material with suitable diameters.
- ✓ Do not operate at temperatures or humidity, etc. beyond the range of specifications.
- ✓ Please do not use it in a dusty place, the place where direct sun beam hit and the environment where corrosive gases exist. If a dew condensation is generated, you should not use the product until it dries completely.
- ✓ Never attempt to perform dismantle or modification. And when the product breaks down, do not repair it by yourself. If the product broke down, please consult to our support dept.
- ✓ Failure to heed this instruction may cause in fire, electric shock, personal injury or malfunction.

1. Cautions on use (continued)

- ✓ Do not touch directly the electrical components which are mounted on the printed wiring board. And please take care not to charge the static electricity to the electrical components.
- ✓ To transport this product, it should be put in the shipping carton, or please put a printed circuit board into an anti-static bag or a conductive bag, and pack up using suitable shock absorbing material so that vibration and a shock are not added.
- ✓ Dispose of the product according to all national laws and regulations.

2. General

- ✓ PLC-24V10AL-PT and PLC-24V10AL-TH are TEC (Peltier) temperature controller.
- ✓ The differences of the specification from the base model PLC-24V10A are as follows.

Item	PLC-24V10A	PLC-24V10AL-PT	PLC-24V10AL-TH
Main temperature sensor	Pt100 / NTC thermistor	Pt100	NTC thermistor (*1)
Peltier driving voltage	3V to 24V	7V to 24V(*2)	
Temperature range	Pt100: -50°C to 150°C NTC thermistor: -40°C to 100°C	-40°C to 100°C	
DC Fan output	Direct / 5V fixed / 12V fixed	Direct	

(*1) NTC thermistor $R_{25}=10k\Omega$. It is selectable the type of NTC thermistor by using the dedicated setting software.

(*2) Driving voltage depends on supply voltage. It can be driven from 0.5 V for dual power supply operation.

- ✓ High driving current up to 10A by the PWM drive
- ✓ The digital PID control
- ✓ Sub temperature sensor for monitoring (NTC thermistor $R_{25}=10k\Omega$)
- ✓ Temperature monitoring function (indicator function)
- ✓ DC fan connection terminal with rotational pulse input
- ✓ Continuous operation and timer operation by stand-alone operation
- ✓ Stackable display board for stand-alone operation
- ✓ When an alarm occurs, the cause code of the alarm is displayed on the display board.
- ✓ External control input (Start / Timer) / Parallel output (Indicator / Alarm)
- ✓ Operation lock function to prevent mis-operation
- ✓ Same form factor (same dimension) as previous model of PLC series (PLC-24V6A, etc.)
- ✓ RS-232 serial communication port
- ✓ It is possible to control from the personal computer by using RS-232 serial command.
- ✓ Free control software and setting software are available from Kurag Electronics website.

3. Contents

- Listed items are included in this product package.
- Please check that these items are included.

Name	Main board	Display board	Main with display
PLC-24V10AL Main Board	✓		✓
PLC-24V10A Display Board		✓	✓
RS-232 Cable	✓		✓
Quick Start Manual	✓	✓	✓

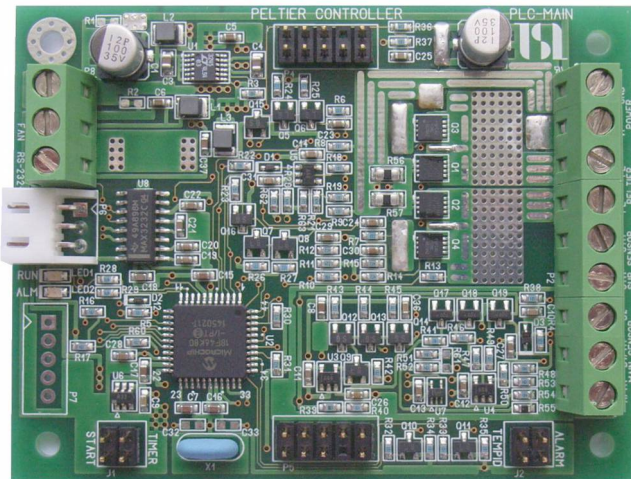

Main board

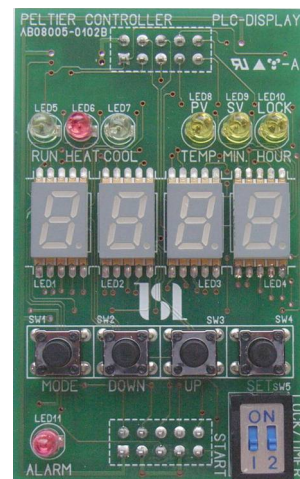

Display board

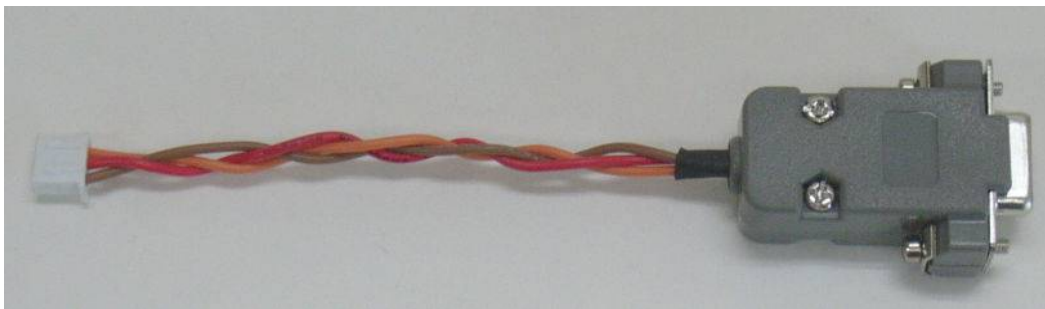

RS-232 cable

* JST XHP-3 to Dsub 9 pin Cable length = 100mm

4. Names of parts and functions (Main board)

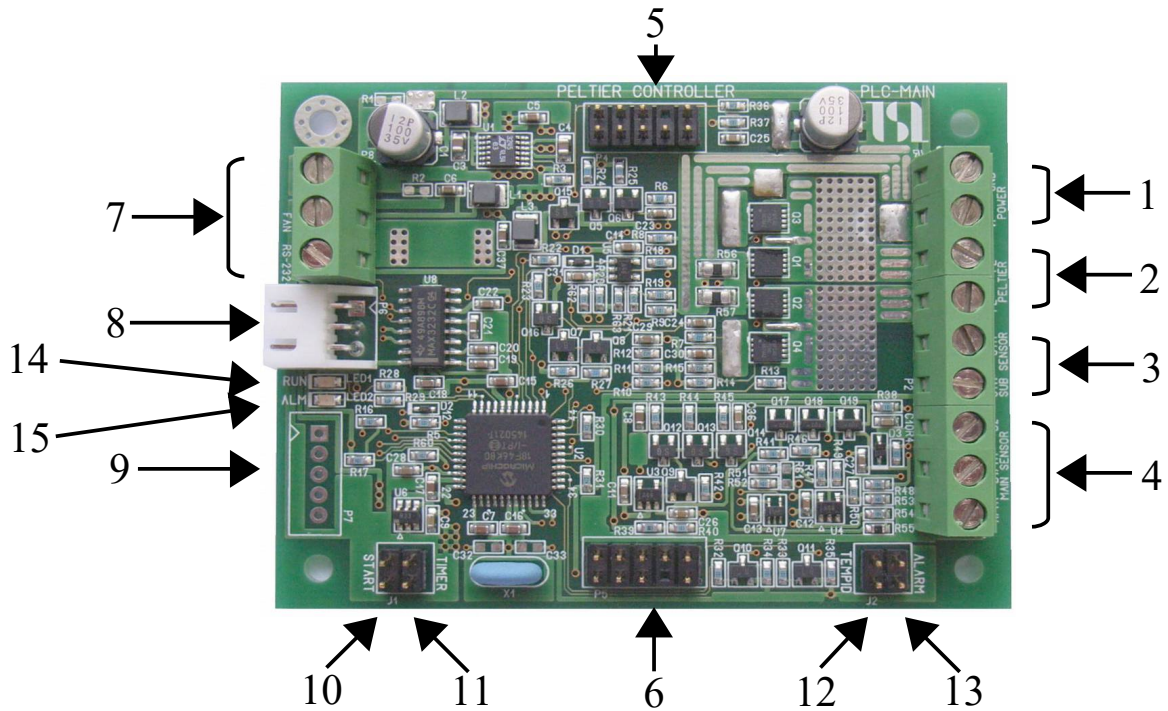

1. Power supply terminal

The range of supply voltage is DC 7V to 24V (single power supply).

2. TEC (Peltier) element terminal

3. Sub temperature sensor terminal

4. Main temperature sensor terminal

5. / 6. Connectors to Display Board

7. DC fan terminal

DC fan terminal for heat sinking. (up to 500 mA)

The same voltage as power supply voltage can be outputted for a standard product.

The fixed voltage of 5V or 12V can be outputted for a customized product.

8. A connector for a RS-232 communication cable

Connector to connect an attached RS-232 cable for external control.

9. The connector for factory use (no part is mounted)

10. / 11. A terminal for external control (START / TIMER)

A start/stop of temperature control operation and timer operation are controllable by connecting and switching on and off for these terminals.

12. / 13. Parallel output (INDICATOR / ALARM)

Open collector outputs to notify the indicator and alarm status.

14. / 15. Status LED lamps (RUN / ALARM)

LED lamps to display the product operation status.

14. RUN: Turn-on during control operation. Blinking during reverse protection

15. ALM; Blinking when alarm occur. Turn-on during temperature indicator works.

* When the display board is connected, these LED lamps are turned-off.

5. Names of parts and functions (Display board)

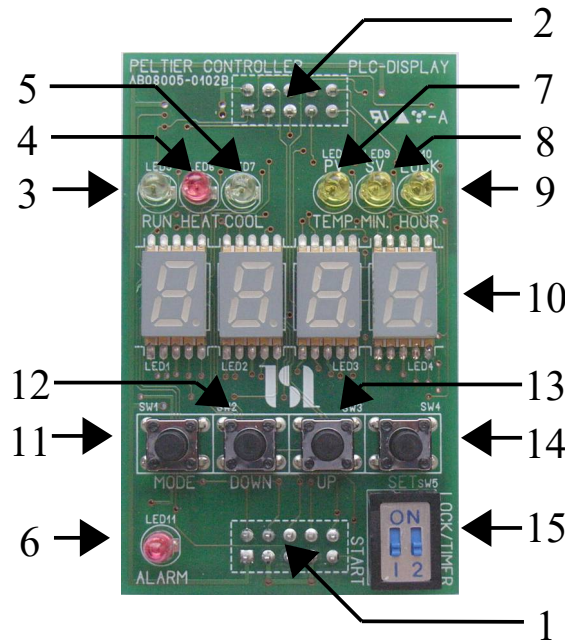

1. / 2. Connectors to Main Board

The connectors combine a display board with a main board.

3. / 4. / 5. Operation status LED lamps

These LED lamps display the product operation status.

- 3. The temperature control is at work: Lights up “RUN” (GREEN)
- 4. The heater mode is at work: Lights up “HEAT” (RED)
- 5. The cooler mode is at work: Lights up “COOL” (GREEN)

6. Alarm LED lamp

When alarm occurred, blinks “ALARM” (RED) and the operation is stopped.

7. / 8. / 9. Display status LED lamps

These LED lamps display the content of 7 segments LED displays. It blinks during a setting and lights up continuously after decision or during display.

- 7. Display the temperature: Lights up “TEMP.” (YELLOW)
- 8. Display the time (unit: minute): Lights up “MIN.” (YELLOW)
- 9. Display the time (unit: hour): Lights up “HOUR.” (YELLOW)

10. 7 segment LED (4 digit)

This LED displays the temperature or time.

11. MODE key 12. DOWN key 13. UP key 14. SET key

These keys are for setting of temperature or timer operation.

15. Operation switch

Position of switch is upper side ON: Start

Position of switch is lower side OFF: Stop

SW1: Start/Stop the continuous operation.

SW2: Start/Stop the timer operation.

6. Setting and connection

6-1. Setting of power supply voltage

This product uses PWM drive. The drive circuit is configured as shown below.

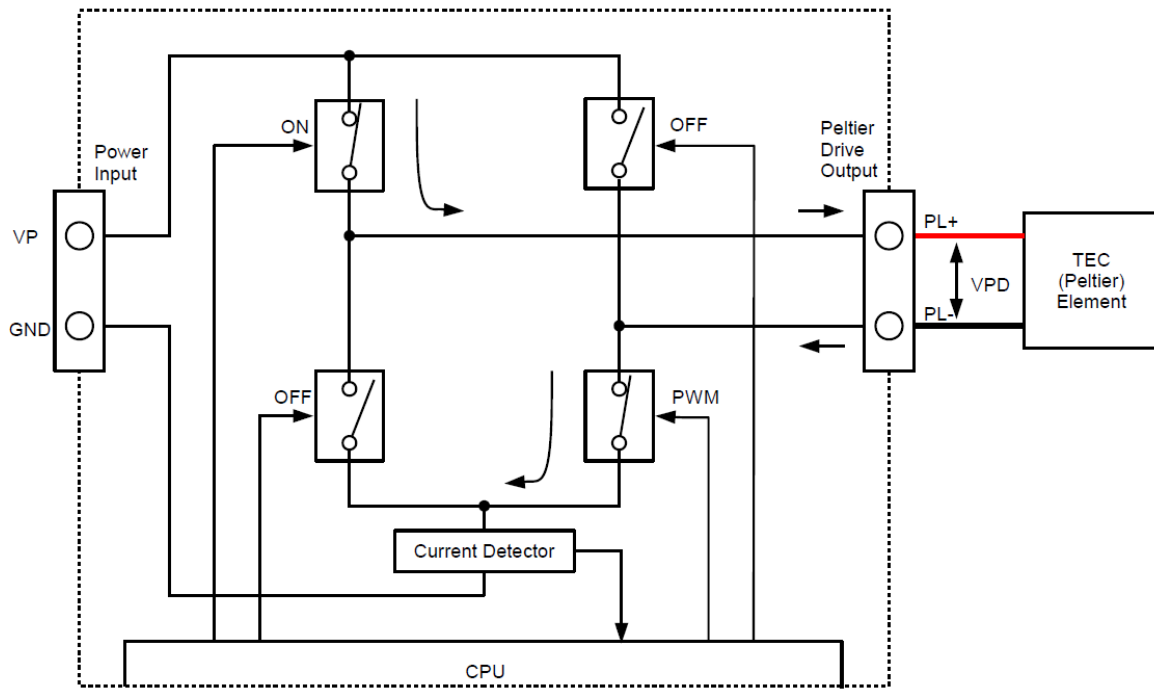

This figure shows the state when driving in the cooling direction. A switching element of a full bridge configuration (actually a semiconductor switch element) by switching on / off the polarity of the Peltier drive output and performing PWM modulation, temperature control is carried out. Since the voltage drop of the switching element and current detection circuit is very small, the driving voltage “VPD” of the Peltier element is almost equal to the power supply voltage “VP”.

* In this product, the filter circuit is not included in the Peltier drive output, so during PWM drive a pulse whose voltage is almost equal to the power supply voltage VP is applied to the Peltier device.

The equivalent circuit when voltage is applied to the Peltier element is as shown below.

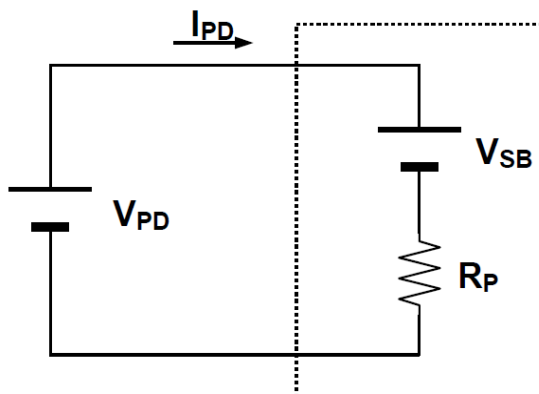

VPD: Peltier driving voltage
 IPD: Peltier driving current
 RP: Internal resistance of Peltier
 VSB: Thermo-electromotive force due to Seebeck effect

* VSB increases as the temperature difference between the heat absorption surface and the heat radiation surface of the Peltier element increases.

Peltier driving current IPD is calculated by the following formula.

$$\mathbf{IPD=(VPD-VSB)/RP}$$

The voltage of the Peltier drive power supply (VP) is needed to set to satisfy the following conditions (1) to (3).

$$\mathbf{(1) VP \approx VPD \leq Vmax}$$
 (Vmax: maximum voltage of the Peltier element)

$$\mathbf{(2) IPD = (VPD - VSB) / RP \leq Imax}$$
 (Imax: maximum current of the Peltier element)

In case that temperature control is always performed at a constant temperature, when VSB = 0 in equation (2), IPD is the maximum. When there is no temperature difference between both surface (for example at the start of temperature control), VSB will be "0".

$$\mathbf{(2-1) IPD = VPD / RP \leq Imax \rightarrow VPD = IPD \times RP \leq Imax \times RP}$$

When repeating cooling / heating, at the moment the driving polarity reverses, the polarity of VSB becomes reverse polarity as the polarity of VPD, IPD will be increased.

$$\mathbf{(2-2) IPD = (VPD + VSB) / RP \leq Imax \rightarrow VPD = IPD \times RP - VSB \leq Imax \times RP - VSB}$$

* By using the drive reversal protection function, excessive current flows in the Peltier element when the drive polarity reverses It can prevent flowing.

For details, please refer to "8-2. Drive reversal protection function" in this document

In addition, the power supply voltage range restricted by the specifications of this product is as follows.

$$\mathbf{(3-1) 7V \leq VP \leq 24V}$$
 (Single power supply)

$$\mathbf{(3-2) 0.5V \leq VP \leq 24V}$$
 (Dual power supply)

6-2. Setting of alarm / protection functions

For alarm / protection function, use the dedicated setting software "PLC-24V10A Manager"

You can enable / disable and set alarm detection judgment value by using.

* For the display of the cause code of the alarm, please refer to "8-1. Alarm function"

The following table shows the guidelines for describing and setting each alarm / protection function.

Name	Description	Guideline
Temperature sensor (Main sensor)	An alarm occurs when the main temperature sensor is not connected or disconnected.	It is recommended to set it to "ON" (Enable).
Temperature sensor (Sub sensor)	An alarm occurs when the sub temperature sensor is not connected or disconnected.	When the sub temperature sensor is used, it is recommended to set it to "ON" (Enable).
Power supply	An alarm occurs when the power supply voltage is out of the preset reference range.	It is normally "OFF" (Disable) and it is no problem. When the power supply voltage is changed dynamically, set it to "ON" (Enable).
Peltier current	An alarm occurs when the Peltier current is out of the preset reference value range.	It is recommended to set it to ON (Enable). Please set the lower limit to 1/10 to 1/5 of the normal current of the Peltier element. Please set the upper limit to less than the maximum current (Imax) of the Peltier element.
Fan stop	When using DC fan with pulse sensor (3 wire type), rotation pulse from fan is not detected about 5 seconds or more, an alarm occurs.	If you do not connect a DC fan with a pulse sensor, set it to OFF (Disable).
Peltier polarity	An alarm occurs when the temperature control operation is continued with the polarity of the Peltier element reversely connected	If the Peltier element is connected to the correct polarity, it is normally OFF (Disable) and there is no problem.
Reverse protection	When the drive polarity is reversed, the temperature control operation is temporarily stopped, and the Peltier element is protected from over current. (It restarts automatically)	In case of repeating cooling / heating, turn ON (Enable) when power supply voltage VP can not satisfy the condition of (2-2) of "6-1. Setting of power supply voltage".

6-3. Setting of temperature sensor type

It is able to select the temperature sensor type by using the dedicated setting software "PLC-24V10A Manager". When ordering, if you specify the temperature sensor type, we will deliver it with the setting corresponding to that temperature sensor.

* Please check the shipment inspection report attached to the product.

If you did not specify the temperature sensor at the time of shipping, the temperature sensor type is set as follows.

Name	Setting of temperature sensor type	Temperature range	Enable / Disable
Main temperature sensor	-PT: Pt100 Platinum RTD $R_{(0^{\circ}\text{C})}=100\text{ohm}$ -TH: SEMITEC 103JT NTC thermistor $R_{25}=10\text{kohm}$ $B_{(25/85)}=3435\text{K}$	-40°C to +100°C	Always enable
Sub temperature sensor	SEMITEC 103JT NTC thermistor $R_{25}=10\text{kohm}$ $B_{(25/85)}=3435\text{K}$	-40°C to +100°C	Disable

* The setting of the temperature range can be made narrower than the range above, but it can not be expanded.

The following temperature sensor type can be selected.

* The NTC thermistor can also be set by entering coefficients of the Steinhart-Hart approximate expression.

Name	Supplier	Parts # ("x" is arbitrary)	Main sensor		Sub sensor
			-PT	-TH	
Pt100	-	-	✓	-	-
SEMITEC 103JT	SEMITEC	103JT-xxx	-	✓	✓
SEMITEC 103ET	SEMITEC	103ET-x-1P	-	✓	✓
SEMITEC 103AT	SEMITEC	103AT-x	-	✓	✓
SEMITEC 103KT	SEMITEC	103KT1608T-1P	-	✓	✓
MURATA NXFT15XH103	Murata	NXFT15XH103FAxBxxx	-	✓	✓
MURATA NXFT15XV103	Murata	NXFT15XV103FAxBxxx	-	✓	✓
OMEGA 44006/44031	OMEGA	44006 or 44031	-	✓	✓
VISHAY NTCLE100E3103	VISHAY	NTCLE100E3103JB0	-	✓	✓
EPCOS B57861S0103	EPCOS (TDK)	B57861S103F040	-	✓	✓

6-4. Setting of PID control parameters

It is able to change the parameter (coefficient) of PID control by using the dedicated setting software "PLC-24V10A Manager".

Guidelines of setting are as follows.

Preset#	Response of the temperature sensor	Guideline of setting		
		Kp	Ki	Kd
9	The sensor is located close to the temperature control surface. Temperature change can be detected with no time lag.	500	0.7	0
5	The sensor is slightly away from the temperature control surface. Temperature change can be detected with a delay of few seconds.	100	0.3	0
1	And the temperature change is detected with a delay of about several seconds. The sensor is far away from the temperature control surface of the Peltier element , And the temperature change is detected with a delay of 10 seconds or more.	15	0.1	0

* If the control is unstable, adjust the parameters according to the technical manual

"PLC-24V10A PID control parameter setting".

6-5. Connection

To connect the screw terminal block, please strip the covering of an electric wire about 5 mm, and insert to the terminal and keep certain tightening torque using screwdriver.

The wire material that is compatible with the screw-type terminal is as follows.

Conductor cross section: 0.05 mm² to 1.31 mm² (AWG # 30 to AWG # 16)

* Please fully loosen the screw before inserting the electric wire.

(1) Connecting the display board to the main board

* The connection is already established in case of main with display set.

Please align the direction of a substrate, and the position of two connectors, and insert straightly.

If the direction is wrong or the position of each connector is shifted, you can not perform the connection physically. In that case, please do not insert by force.

(2) Connecting power supply

Connection method differs depending on single power supply and dual power supply.

Also, in order to switch between single power supply and dual power supply, it is necessary to open / short the solder short pad on the back of the main board with a soldering iron.

* When there is no designation at the time of ordering, it is set for single power supply.

Name	Terminal	Fan output direct	
		Single power supply	Dual power supply
SPx	SP2	Short	Open
	SP3	Open	Short
	SP4	Short	Short
	SP5	Short	Open
	SP6	Open	Open
POWER	VP	+ (DC 7V to 24V)	For Peltier drive + (DC 0.5V to 24V)
	GND	- (GND)	For Peltier drive - (GND)
FAN	F+	Connect DC Fan	For control circuit + (DC 7V~24V)
	F-		For control circuit - (GND)

* Please use a wiring material with sufficient current capacity.



Position of short pad (Bottom side of main board)

* Resettable fuses may be mounted between SP2 and SP3 depending on production lot.

* The picture shows the setting of dual power supply. (SP 2 is open, SP 3 is short, SP 5 is open)

* SP1 is a short pad for connecting circuit GND to FG (chassis ground).

(3) Connecting Peltier element

Name	Pin	Connection
PELTIER	PL+	Please connect the each lead wire of Peltier device respectively as follows. The surface of Peltier device which should be temperature-controlled is cooling when a current flows from PL+ to PL-.
	PL-	

* Please use a wiring material with sufficient current capacity.

(4) Connecting temperature sensor

Name	Pin	PLC-24V10AL-PT		PLC-24V10AL-TH
		3-wire Pt sensor	2-wire Pt sensor	NTC thermistor
MAIN SENSOR	A/TH+	A	A	Th+
	B1/TH-	B	B	Th-
	B2	B	Short with B1/TH-	Open

Name	Pin	NTC thermistor
SUB SENSOR	STH+	Th+
	STH-	Th-

* Only NTC thermistor is supported as the sub sensor. Pt sensor can not be connected to the sub sensor.

(5) Connecting DC fan

Name	Pin	Connection
FAN	F-	GND
	F+	Vcc * Please connect after checking the rated voltage of the fan motor.
	FS	PULSE * Please connect if a pulse sensor is equipped.

* In case of a standard product, the same voltage as power supply voltage is output to F+ (Vcc).

* In case of a customized product, the fixed voltage of 5V or 12V is output to F+ (Vcc).

(6) Connecting of communication cable

When you want to operate this product by communication commands, please connect the attached RS-232 communication cable.

*Do not connect any cable except for the attached RS-232 communication cable.

Location of connection terminals

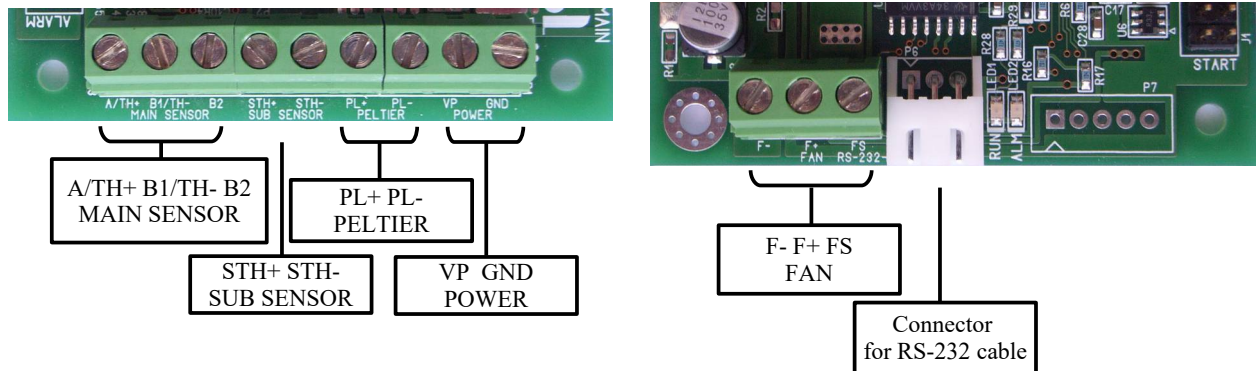

(7) Connection of main board external control terminal

It is a 2.54 mm pitch pin header.

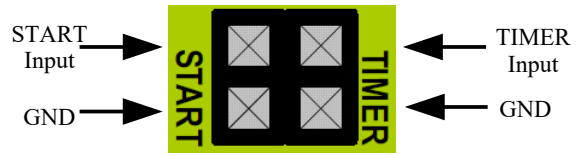

Short socket, switch, photo coupler, relay etc. between terminals

By shorting / opening, it is possible to start / stop the temperature control operation and start / stop the timer operation.

- * It has the same function as the operation control switch of the display unit (equivalent to being connected in parallel).
- * Since it is pulled up by the internal circuit, please do not apply the voltage signal.

(8) Connection of main unit parallel output terminal

It is a 2.54 mm pitch pin header.

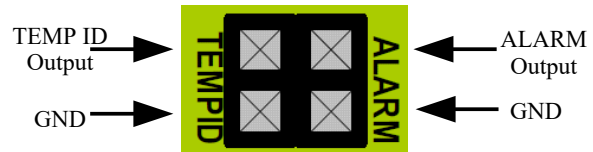

It is two open collector outputs, and it is output as follows depending on the indicator and alarm occurrence situation.

Name	Temperature is within the reference range	Temperature is out of the reference range
TEMPID	OPEN	LOW

Name	No alarm has occurred	An alarm has occurred
ALARM	OPEN	LOW

- * The GND terminal is connected to the internal circuit GND and is not insulated. When connecting to an external circuit, please insulate with photo coupler etc. as necessary.
- * When pulling up to the outside, make sure that the voltage is 24 V or less and the current is 50 mA or less.

6-6. Connection diagram (Single power supply)

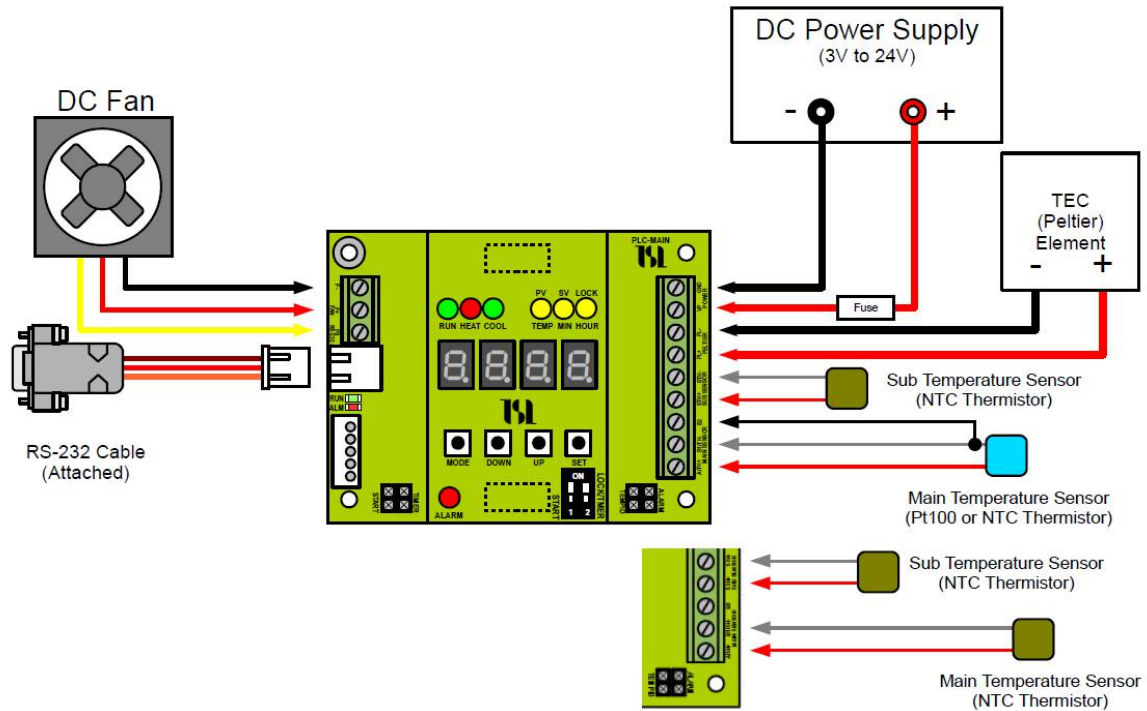

6-7. Connection diagram (Dual power supply)

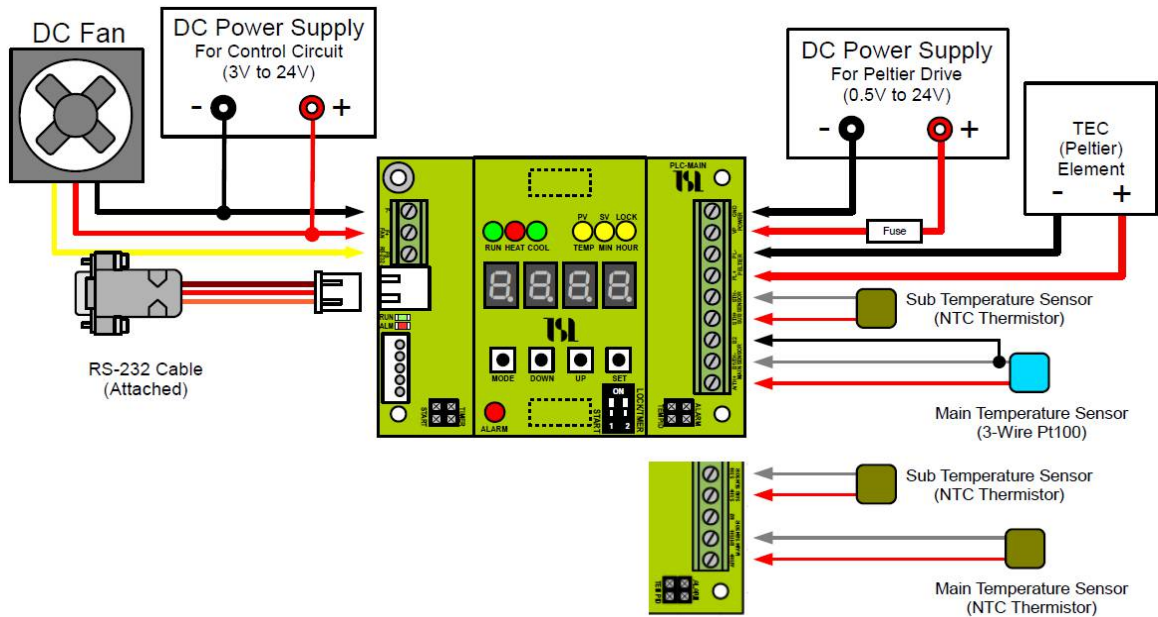

* When 2-wire Pt100 sensor is used, short-circuit between the B1 terminal and the B2 terminal.

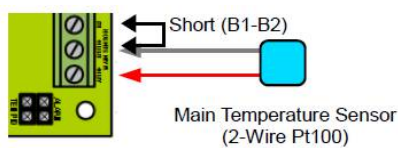

* When the wiring of the temperature sensor is long, it is recommended to use a shielded wire to reduce the influence of external noise.

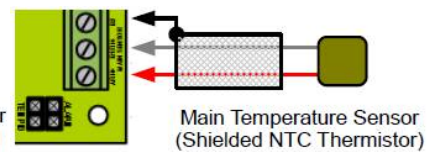
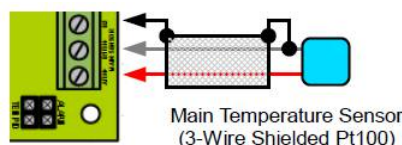

7. Operation

There are two types of modes that can be operated as “Continuous mode” and “Timer mode”. In addition, you can select either “Timer mode” or “Lock mode” by using the dedicated setting software "PLC-24V10A Manager".

- * When the lock mode is selected, the operation procedure will change, timer operation can not be performed by stand-alone operation. Even in this case, timer operation by communication command is possible.
- * When there is no designation at the time of ordering, it is set "Timer mode".

7-1. Basic operation by key operation (when “Timer mode” is selected)

Every time when MODE key is pushed, the display of 7 segment LED changes as follows.

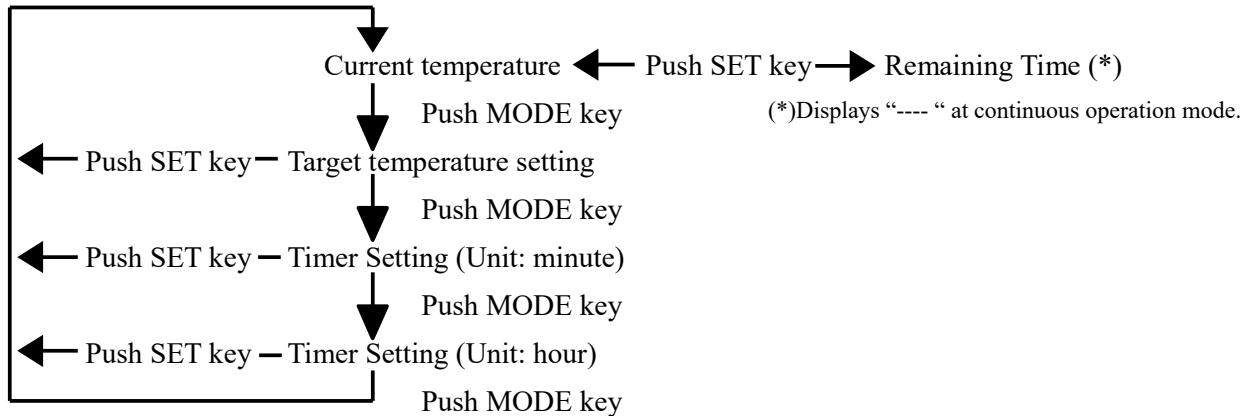

7-2. Temperature indication of sub temperature sensor

If you press and hold the MODE key during the current temperature display, the temperature of the sub temperature sensor will be displayed while pressing the MODE key. TEMP. LED turns off during sub temperature sensor temperature display.

Release the MODE key to return to the temperature display of the main temperature sensor.

- * If the sub temperature sensor is disabled or the sub temperature sensor is not connected, the incorrect temperature may be displayed.

7-3. Operation procedure of continuous mode (when “Timer mode” is selected)

- 1) Pressing the MODE key to change the display to the target temperature setting mode. (TEMP. LED blinks)
- 2) Set the desired temperature using UP/DOWN keys.
 - * A fast setting is available by pressing the button continuously.
 - * The target temperature can be set within the preset temperature range.
- 3) Pressing SET key to complete the target temperature. (Displays current temperature)
- 4) Slide the START switch to “ON”. (Start the temperature control)
- 5) Slide the START switch to “OFF”. (Stop the temperature control)
 - * The target temperature is stored in the memory even if the power is turned off.

7-4. Operation procedure of timer mode

- 1) Set the target temperature using UP/DOWN keys as same as continuous mode.
- 2) Press the MODE key to display the timer setting mode (unit: minute or hour).
(MIN. or HOUR LED blinks)
- 3) Press the UP/DOWN keys to change the timer setting.
 - * A fast setting is available by pressing the button continuously.
- 4) Press the SET key to complete the timer setting. (Displays current temperature)
 - * The unit of “minute” or “hour” which was set up at the last becomes effective.
- 5) Slide the timer switch of this unit to “ON”. (Start the timer)
 - * If a start switch is already “ON”, the timer mode is started from that point.
 - * If a START switch is turned off, slide both of START switch and TIMER switch to “ON” simultaneously.
- 6) A remaining time of timer is displayed if the SET key is pressed.
(Displays current temperature if the SET key is pressed again)
- 7) When the timer reached the setup time, the operation is automatically stopped.
 - * If a TIMER switch is turned off before the end of a timer, temperature control is kept in the continuous mode.
 - * If a TIMER switch is turned off and turned on again, the timer will start again from the beginning.
 - * The setting of the timer is stored in the memory even if the power is turned off.

7-5. Operation procedure of lock mode (when lock mode is selected)

The lock mode is a mode to restrict operation so that careless target temperature setting is not changed.

During the lock mode, the LOCK LED on the indicator lights up.

Temperature control start / stop operation with START switch is also possible in lock mode.

The state of the operation restriction changes with ON / OFF of the operation switch LOCK.

When the LOCK switch is ON

The target temperature can not be changed.

Each time the MODE key is pressed, the display of the current temperature and the target temperature is toggled.

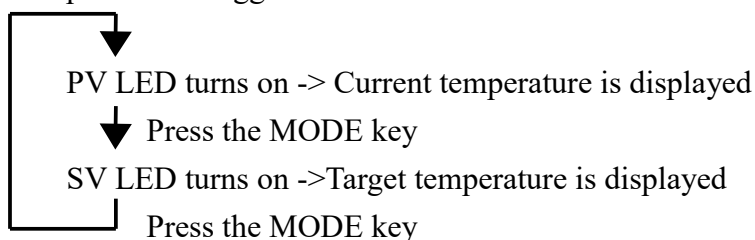

When the LOCK switch is OFF

The target temperature can be changed by the following procedure.

(1) Press and hold the SET key until the SV LED blinks.

(2) Press the UP / DOWN key to change the target temperature.

* When the upper limit and lower limit of the set temperature range are reached, even if you press the UP / DOWN key, the number does not change.

(3) Press the SET key to set the target temperature.

* The PV LED lights up and returns to the current temperature display.

8. Alarm / Protect / Indicator functions

Each function can be set to ON or OFF by the dedicated software.

Moreover, change of a detection reference value can be changed about some functions.

8-1. Alarm functions

This product has the following alarm functions. When an alarm occurs, the alarm indication LED blinks, the cause code is displayed on the indicator, and the temperature control operation stops.

Turn off the temperature control switch once, remove the cause of alarm, turn it on again and the temperature control operation resumes.

Name	Cause code	Description
Temperature sensor	Main: - - - 1 Sub: - - - 7	An alarm occurs when the temperature sensor is not connected or disconnected.
Power supply	Under: - - - 3 Over: - - - 4	An alarm occurs when the power supply voltage is out of the preset reference range.
Peltier current	Under: - - - 5 Over: - - - 6	An alarm occurs when the Peltier current is out of the preset reference value range.
Fan stop	- - - 2	When using DC fan with pulse sensor (3 wire type), rotation pulse from fan is not detected about 5 seconds or more, an alarm occurs.
Peltier polarity	- - - 8	An alarm occurs when the temperature control operation is continued with the polarity of the Peltier element reversely connected

8-2. Reverse protection

This function prevents over current from flowing to the Peltier element when the drive polarity is reversed.

- * This function is unnecessary when controlling to constant temperature at all times.
- * It is effective when there is a possibility that a current exceeding the maximum current (I_{max}) may flow to the Peltier element when the drive polarity reverses.
- * Temperature control temporarily stops, so it is not suitable when you want to rapidly raise or lower the temperature.

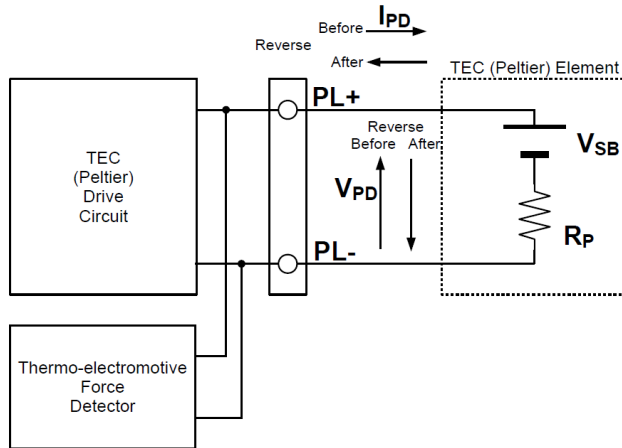

VPD: Peltier driving voltage
 IPD: Peltier driving current
 RP: Internal resistance of Peltier
 VSB: Thermo-electromotive force due to Seebeck effect

* VSB increases as the temperature difference between the heat absorption surface and the heat radiation surface of the Peltier element increases.

Operating principle

- (1) When driving polarity is reversed, driving of the Peltier element is temporarily interrupted.
- (2) Monitor the thermo-electromotive force (VSB) generated inside the Peltier element.
- (3) When the thermo-electromotive force (VSB) is larger than the set reference value, it maintains the drive stop state until the value becomes smaller than the reference value, and then automatically resumes driving.

* The RUN LED blinks during reverse protection is in progress. It turns on when driving resumes.

Setting of criterion value (threshold)

$$IPD = (VPD + VSB) / RP \leq I_{max} \text{ (} I_{max}: \text{ maximum current of the Peltier element)}$$

$$VSB \leq I_{max} \times RP - VPD \approx I_{max} \times RP - VP \text{ (} VP: \text{ Peltier drive power supply voltage)}$$

(Example) When $I_{max} = 8 \text{ A}$, $RP = 2 \text{ ohm}$, $VP = 15 \text{ V}$

$$VSB \leq 8 \times 2 - 15 = 1 \text{ V}$$

Setting the judgment reference value to 1 V or less protects the Peltier element from over current.

- * If the judgment reference value is too small, it will take a long time to resume driving.
 - * Because there is a temperature difference in the Peltier element due to heat generation of the temperature controlled object, the thermo-electromotive force
- If it has occurred, protection started from the beginning, temperature control operation can not be started.

8-3. Indicator function

It monitors the temperature of the main temperature sensor and the sub temperature sensor, determines whether the temperature is within or outside the set reference value, and outputs it to the display and the parallel output terminal.

The reference value can be set independently for the main temperature sensor and the sub temperature sensor, but if either one is out of the reference value range, the display and the parallel output change.

* Unlike the alarm function, the temperature control operation does not stop automatically even if the indicator function works.

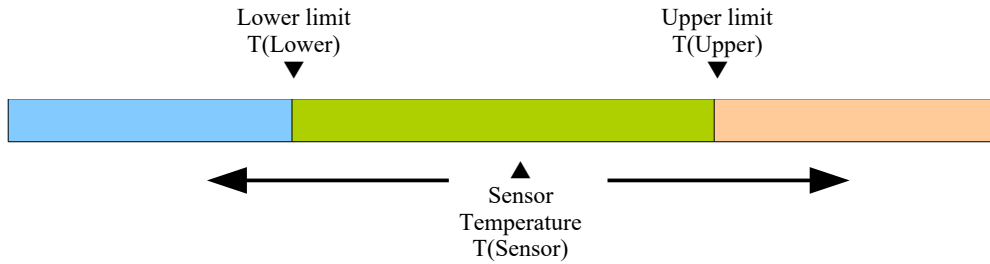

Condition	ALARM LED	Parallel output (TEMP ID)
$T(\text{Sensor}) < T(\text{Lower})$	Turn on	LOW
$T(\text{Upper}) \leq T(\text{Sensor}) \leq T(\text{Lower})$	Turn off	OPEN
$T(\text{Sensor}) \geq T(\text{Upper})$	Turn on	LOW

* When Upper limit = Lower limit = 0°C, the indicator function will be disabled.

Example of use

- (1) Set the lower limit and the upper limit to -1°C and + 1°C, and check that the current temperature is within ±1°C of the target temperature or not.
- (2) Attach the sub sensor to the heat sinking surface of the Peltier element and warn if the heat sinking surface temperature rises abnormally.
- (3) Attach the sub-sensor to the heat sinking surface of the Peltier element and increase the air flow rate of the cooling fan when the temperature of the heat sink rises.

* External circuit is required.

9. Specifications

Item	PLC-24V10AL -PT	PLC-24V10AL -TH	Remarks
Power supply	DC 7V to 24V		Single power supply
Consumption (Main)	150mA (Max)		Not include Peltier drive current and DC fan drive current
Consumption (Display)	90mA (Max)		
Peltier drive voltage	7V to 24V		Single power supply, 0.5V to 24V on dual power supply
Peltier drive current	10A (Max)		Limited by the internal resistance and the thermo-electromotive force of Peltier element
Peltier drive method	PWM		Cooling / Heating bipolar drive
Main temperature sensor	Pt100 (*1)	NTC thermistor (*2)	(*1) 3-wire and 2-wire Pt sensor are supported (*2) Sensor type is selectable by the setting software
Sub temperature sensor	NTC thermistor		* Sensor type is selectable by the setting software
Control method	Digital PID Control		
Control temperature range	-40°C to +100°C		
Setting / display resolution	0.1°C		
Timer range	0.1min to 999.9min 0.1hour to 720hour		Accuracy of time: +/-1%
Operation temperature/ humidity	10 to 40°C / 5 to 85%RH		No condensation
Storage temperature/ humidity	-20 to 60°C / 5 to 90%RH		No condensation

TEC (Peltier) Controller PLC-24V10AL Reference Manual

Date: April 5, 2017 (Rev.1.00)

Developer: T.S. Laboratory Corporation URL <http://tslab.com/>

Manufacturer: Kurag Electronics LLC URL <http://kurag.o.oo7.jp/kurag-el/>